

EBBCO POWER 240-3PH-60HC
11KVA 14A

2.0 CFM AT 90 PSI
* NOTE FILTERED
AIR REQUIRED

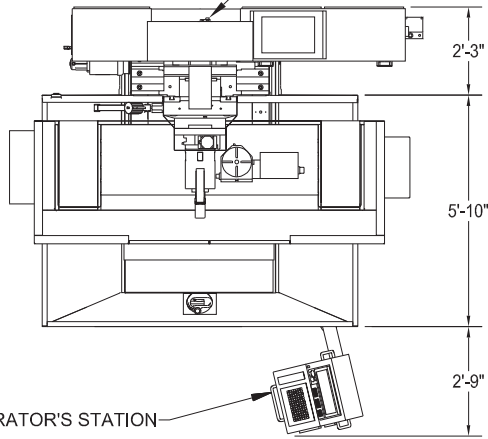

OPERATOR'S STATION

TOP VIEW

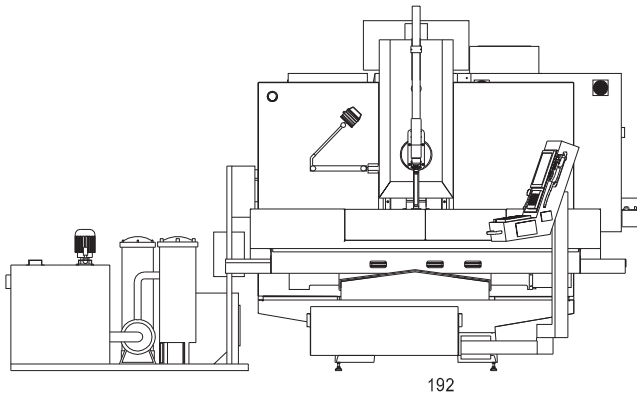
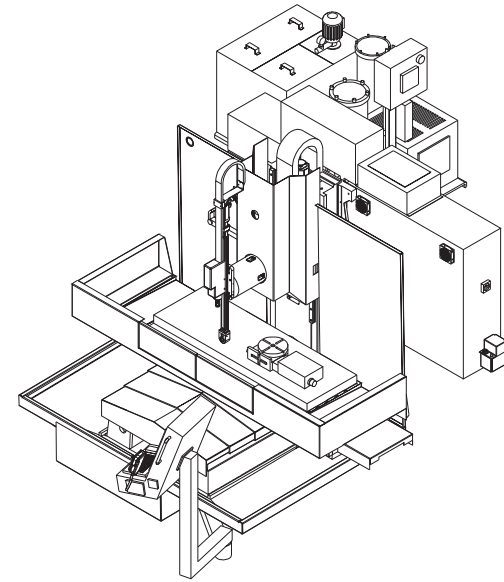

MACHINE VOLTAGE IS
240V-3PH-60 HZ
FLA-60 AMPS

FRONT VIEW

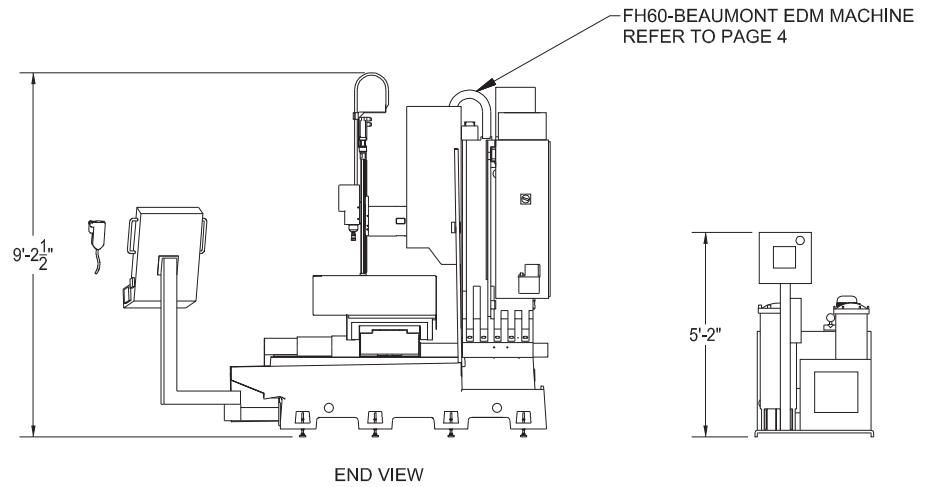

▲ RECOMMENDED PLACEMENT OF POWER TRANSFORMER IS 34" HIGH